

Ultra-low-power RADFET Sensing Circuit for Wireless Sensor Networks Powered by Energy Harvesting

A. Somov, Z. J. Chew, T. Ruan, M. Zhu

College of Engineering, Mathematics and Physical Sciences
University of Exeter
Exeter, England

S. P. Platt

School of Engineering
University of Central Lancashire
Preston, England

Abstract—We evaluate an ultra-low-power radiation-sensing circuit based on a radiation sensitive MOSFET (RADFET) for use in Wireless Sensor Networks (WSN) powered by energy harvesting with a special focus on airborne applications. We estimate a worst-case energy budget below 10 μJ per readout cycle superimposed on a constant worst-case power budget below 10 μW . The sensor circuit operates successfully with a wireless sensor node powered by a piezoelectric harvester and power management unit which is able to provide up to 2.5 mW at 10 Hz, 600 μs in emulated flight mode.

Keywords—energy harvesting; low-power design; RADFET; radiation monitoring; wireless sensor network

I. INTRODUCTION

The Wireless Sensor Network (WSN) paradigm has been recently applied to many monitoring scenarios [1],[2] including structural health monitoring of aircraft [3] in flight. Indeed, it is essential to identify potential structural cracks or reveal a damage at an early stage, e.g. monitor bird impact using an accelerometer. Another class of sensing, which might be of interest for High-Altitude Long-Endurance (HALE) Unmanned Air Vehicles (UAVs), is ionizing radiation dosimetry for investigating cosmic rays.

Radiation dosimeters based on radiation sensitive MOSFETs (RADFETS) are well known. A RADFET [4],[5] is an integrating dosimeter formed from a p-channel enhancement-mode MOSFET optimised for sensing ionizing radiation from charged particles or high-energy photons. RADFETs are widely used for dosimetry in space [6]-[8], at particle accelerators and other nuclear facilities [9]-[11], and in radiotherapy applications [12]-[14].

Although most RADFET applications are in wired systems, RADFETS appear well suited to low-power and wireless sensing and some such systems have been considered [13]. Here we consider their suitability for use in an energy-constrained wireless sensor node for potential application to monitor environmental radiation for example in HALE UAVs. In particular, we implement an ultra-low power RADFET sensing circuit, interface it with a wireless sensor node and demonstrate how the entire system is successfully powered by a piezoelectric energy harvester and associated power management system.

II. PLATFORM DESIGN

In this section we describe the RADFET sensing circuit and demonstrate how it can be enriched with wireless and processing capabilities by interfacing with an embedded wireless platform.

A. RADFET Sensing Circuit

The sensing circuit (Fig. 1) is built around the Tyndall TY1003 RADFETs [15]. In irradiation mode all terminals are shorted. Exposure to ionizing radiation during irradiation mode leads to an increase in the threshold gate-source voltage (at which the channel becomes conductive). That threshold voltage can be measured (readout mode) by shorting the RADFET drain and gate and injecting a current at the source terminal. Normal operation of a RADFET sensor has a low duty cycle: terminals are grounded, and therefore no power is consumed by the RADFET, for most of the sensor operation; when a measurement is to be made a current is injected and corresponding measurement made at the source terminal. To first order, the change in the measured threshold voltage between any two time instants is a measure of the total dose received by the sensor during the corresponding time interval.

In readout mode the RADFET is driven by an LM334 constant current source, controlled by an ADG884 analog switch. We made experiments at 10 μA and 100 μA , controlled by a spare switch in the ADG884. A unity gain buffer was used to interface the RADFET to an ADC.

B. Wireless Sensor Node

The block diagram of the wireless sensor node is shown in Fig. 2. The sensor node consists of four units: processing, sensing, wireless communication and power supply. The processing and wireless units are realized using the wireless controller JN5148. It is interfaced with the RADFET sensing circuit by (i) two input-output ports which set the duty cycle for the sensing circuit and controlling Op-Amp, (ii) built-in ADC for receiving the analog data from the RADFET and consequent data transmission to the user over the wireless network. For transmitting the data we use the integrated wireless transceiver. As an autonomous power supply we use an energy harvester which we describe in next section. We note here that the wireless sensor node is designed for the proof-of-concept purpose.

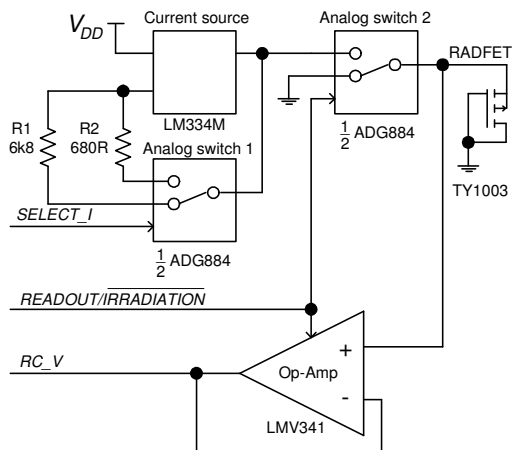

Fig. 1. RADFET sensing circuit schematic.

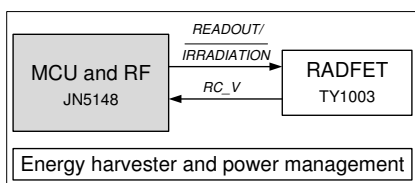

Fig. 2. Block diagram of prototyped wireless sensor node.

C. Energy Harvesting

For powering the sensor node we use a piezoelectric energy harvester: Macro-Fibre Composite (MFC) M8528-P2 material 85x28x0.3 mm which is able to harvest wing vibrations and supply the system. We power the sensor node via a power management circuit [16] which acts as a stable power supply and can generate up to 2.5 mW from strain loading of 600 $\mu\epsilon$ at 10 Hz. More details on powering the wireless sensor node using the energy harvester are provided in next section.

III. EXPERIMENTAL RESULTS

In this section we present the experimental results on the investigation of transient process of RADFET sensor and discuss the power consumption and its optimization.

A. Sensor Transient Response

Fig. 3 and Fig. 4 show example circuit responses. At 10 μA drive current the steady-state response is 1.45 V, at 100 μA it is 2.65 V.

Experimental results shown in Fig. 4 show the turn-on behavior and is helpful for optimizing the readout period which influences the energy consumption of the sensor node. The turn-on transients are characteristic of the current source and are not limited by any characteristic of the RADFET. At both current levels under investigation the sensor response reaches steady state within 1 ms.

B. Power Consumption

Low-power consumption of the sensing circuit is achieved by (i) low-power sensing circuit design and (ii) low duty cycling. Low-power design includes low-power hardware, design principles, circuit optimization (see Section II-A). Low duty cycling is a primary strategy in energy harvester powered WSN

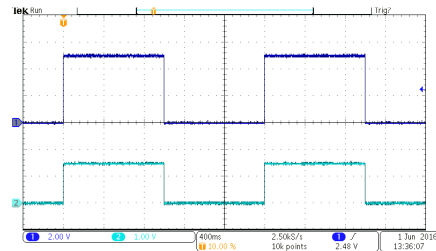
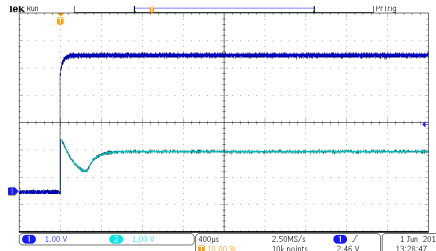
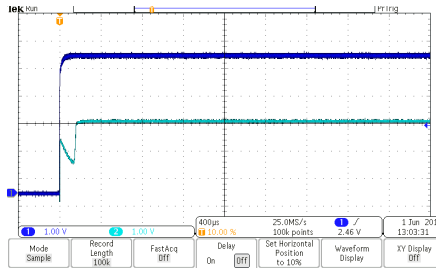

Fig. 3. Voltage supply square wave signal (top) and sensing circuit response 1.45 V (bottom) at 10 μA driving current.



(a)



(b)

Fig. 4. RADFET transient process at (a) 10 μA , (b) 100 μA drive current.

design due to limited energy resources on board autonomous sensing devices. Most of the time the sensor nodes are in sleep mode, wake up for a short period of time for measuring a physical phenomenon and synchronization purposes and go back in sleep mode. To ensure low power consumption the measurement procedure, e.g. its time, can be optimized as discussed in Section III-A by setting proper measurement period.

We made current measurements using a Keithley 2612B sourcemeter. For the circuit of Fig. 1 the current budget in readout mode is dominated by the op-amp supply. For 10 μA RADFET current measured values are less than 80 μA at 3.3 V supply; a worst-case estimate using manufacturers' data is approximately 0.2 mA at 10 μA RADFET current, 0.3 mA at 100 μA . In irradiation mode the current budget is due to the op-amp supply current in shutdown and the analog switch supply. We measured less than 10 nA at 3.3 V; worst-case estimate is 2 μA . Corresponding power consumptions are 250 μW in readout mode (0.7 mW worst case) 30 nW in irradiation mode (7 μW worst-case).

RADFETs are well-suited to low duty cycle operation. In this case, we have confirmed that the circuit reaches steady state within 1 ms; making an allowance for repeated measurements

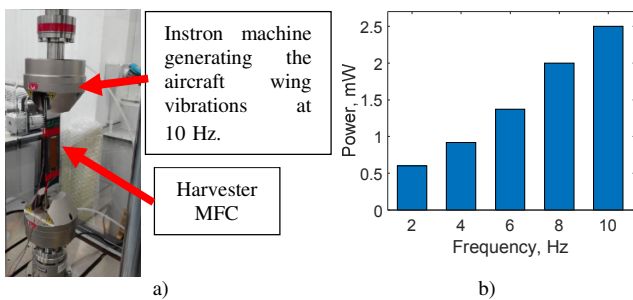

Fig. 5. (a) Testbed for energy harvester assessment and (b) power available from the harvester and power management at 600 $\mu\epsilon$.

we estimate a measurement duration of no more than 10 ms for one readout cycle and expect readout cycles separated by many minutes or several hours. Assuming readout duration to be 10 ms we conclude a worst-case energy budget below 10 μJ per readout cycle superimposed on a constant worst-case power budget below 10 μW .

The main disadvantage of RADFETs is their relatively low sensitivity. The sensitivity of the Tyndall TY1003 RADFETs is approximately 50 mV/Gy(Si) for ^{60}Co photons. Sensitivity is characterised by RADFET batch; initial threshold voltage is measured by device and is typically 1.5 V for our devices. With an ADC reference voltage 2.5 V and 12-bit ADC our initial design has an estimated measurement range of 20 Gy and a resolution 1.25 cGy.

C. Energy Harvesting

In this experiment our goal is to figure out whether the energy harvester described in Section II-C can (i) continuously power the RADFET sensing circuit and (ii) how often the wireless sensor node can send the measured data over wireless channel depending on the available energy.

The experiment starts by setting the harvester in Instron E10000 machine (see Fig. 5a) which generates aircraft like vibrations in flight mode. The energy harvester and power management unit provide stable 3.3 V, 2.5 mW at 10 Hz and 600 $\mu\epsilon$ (see Fig. 5b). The first experiment is successful since the system has enough energy harvested budget for powering the RADFET sensing circuit only. The results of the second experiment demonstrated that the radiation measurement together with the consequent data transmission are possible every 5 s in the best case. Since the radiation level does not change drastically, this time period can be increased to ensure energy buffering or adding extra sensors to this monitoring system.

IV. CONCLUSIONS AND FUTURE WORK

In this paper, we have evaluated a low power design of RADFET sensing circuit and demonstrated its integration with a wireless sensor node aiming at the aircraft monitoring applications. Current consumption of the sensing circuit was measured at less than 80 μA in readout mode and less than 10 nA in irradiation mode (corresponding to sleep mode of the wireless sensor node).

The sensing circuit is characterised by fast response time and can operate at low duty cycle which opens wide vista for its

usage in WSN monitoring applications.

Our future work includes the design of a complete autonomous monitoring solution for aircraft industry. The autonomous operation will be achieved by adopting piezoelectric energy harvesting technology which is able to harvest the aircraft wings' vibrations and use them for powering the wireless sensor nodes including RADFETs in the sensor suite. RADFETs are well suited for this application from the point of view of power and energy budget; their main disadvantage being their relatively low sensitivity. Solutions to address low sensitivity are available and require further investigation to assess their compatibility with our power source. Other open questions include the effect of an ionizing radiation environment on quiescent current in support circuits.

REFERENCES

- [1] G. P. Picco, D. Molteni, A. L. Murphy, F. Ossi, F. Cagnacci, M. Corrà, S. Nicoloso, "Geo-referenced proximity detection of wildlife with WildScope: design and characterization," Proc. 14th Int. Conf. Information Processing in Sensor Networks (IPSN '15), 238-249.
- [2] A. Somov, A. Baranov, D. Spirjakin, A. Spirjakin, V. Sleptsov, R. Passerone, "Deployment and evaluation of a wireless sensor network for methane leak detection," Sensors and Actuators, A: Physical, vol. 202, pp. 217-225, 2013.
- [3] J. Demo, A. Steiner, F. Friedersdorf, M. Putic, "Development of a wireless miniaturized smart sensor network for aircraft corrosion monitoring," Aerospace Conf. 2010, pp. 1-9.
- [4] A. Holmes-Siedle, "The space-charge dosimeter: General principles of a new method of radiation detection," Nucl. Inst. Meth. vol. 121 no. 1, pp. 169-179 Oct. 1974
- [5] A. Holmes-Siedle and L. Adams, "RADFET: A review of the use of metal-oxide-silicon devices as integrating dosimeters", Int. J. Radiat. App. Inst. C. Radiat. Phys. Chem., vol. 28 no. 2, pp. 235-244, 1986
- [6] Y. Kimoto, A. Jaksic, "RADFET utilization for spacecraft dosimetry," Proc. 24th Int. Conf. Microelectronics, pp. 657-659, 2004.
- [7] A. G. Holmes-Siedle, J. O. Goldsten, R. H. Maurer, P. N. Peplowski, "RADFET dosimeters in the belt: the Van Allen probes on Day 365," IEEE Trans. Nucl. Sci., vol. 61, no. 2, pp. 948-954, April 2014.
- [8] P. Falke, H.-H. Fischer, K. J. Seidensticker, K. Thiel, H. Fischer, M. Hilchenbach, H. Henkel, A. Koch, "Cosmic ray dose monitoring using RadFET sensors of the Rosetta instruments SESAME and COSIMA," Acta Astronautica, in press 2016
- [9] B. Camanzi et al., "The BaBar RadFET monitoring board," IEEE Trans. Nucl. Sci., vol. 49, no. 3, pp. 1275-1280, Jun 2002.
- [10] A. Holmes-Siedle, F. Ravotti and M. Glaser, "The Dosimetric Performance of RADFETs in Radiation Test Beams," 2007 IEEE Radiat. Effects Data Workshop Record, pp. 42-57.
- [11] L. Fröhlich, K. Casarin, E. Quai, A. Holmes-Siedle, M. Severgnini, R. Vidimari, "Online monitoring of absorbed dose in undulator magnets with RADFET dosimeters at FERMI@Elettra," Nucl. Inst. Meth. Phys. Res. A, vol. 703, pp.70-79, Mar. 2013
- [12] N. D. Vasović, G. S. Ristić, "A new microcontroller-based RADFET dosimeter reader," Radiat. Meas., vol. 47, no 4, pp. 272-276, Apr. 2012.
- [13] A. Jaksic, K. Rodgers, C. Gallagher, P. J. Hughes, "Use of RADFETs for quality assurance of radiation cancer treatments," Proc. 25th Int. Conf. Microelectronics, 2006, pp. 540-542.
- [14] A. M. McGarrigle, A. Jaksic, A. Mathewson, "Characterisation of RADFET devices at the diagnostic energy range", Abst. Irish Assoc. Phys. Medicine 6th Ann. Sci. Meet., Physica Medica, vol. 32 no. 2, p. 418 Feb 2016
- [15] RADFET Tyndall TY1003 technical data [Online], www.tyndallworks.com/downloads/P-Channel-RADFET-1003-DS.pdf
- [16] Z. J. Chew and M. Zhu, "Low power adaptive power management with energy aware interface for wireless sensor nodes powered using piezoelectric energy harvesting," Proc. IEEE SENSORS 2015, pp. 1-4.