

**TECHNICAL DATA**
**VT01**
**400nm RADFET**
**in 6L SOT-23 Plastic package**
**For doses between 1cGy (1rad) and 1kGy (100krad)**
**VT01 Description and Pin-Out**

The VT01 is Varadis 400nm RADFET chip packaged in plastic SOT-23 six lead package. The part consists of two identical RADFETs, R1 and R2, and a diode (see Figure 1 and Table 1). The RADFETs' gate oxide thickness is 400nm and W/L is 300 $\mu$ m/50 $\mu$ m. The RADFETs have individual gate and drain terminals, while the source and bulk are common and connected together; this is also the diode bulk contact.

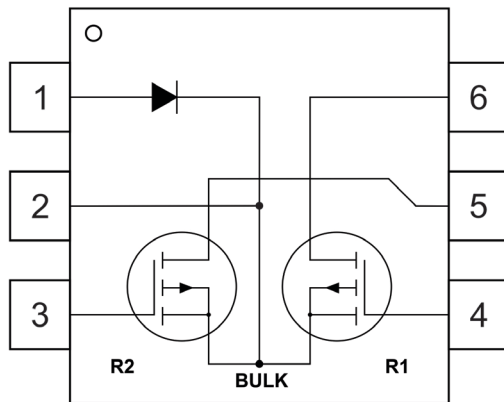

**Figure 1:** VT01 pin-out drawing.

**Table 1:** VT01 pin-out description.

Pin Number	Description
1	Diode Anode <sup>1</sup>
2	Source/bulk (common)
3	Gate of R2
4	Gate of R1
5	Drain of R2
6	Drain of R1

**Maximum Ratings**

Maximum ratings of the VT01 RADFET are given in Table 2.

**Table 2:** Maximum ratings of the VT01. Measured at room temperature.

Characteristics	Symbol	Specification	Unit	Remarks
Drain-Source Voltage	$V_{DS}$	-25	V	
Gate-Source Voltage	$V_{GS}$	$\pm 50$	V	
Drain-Gate Voltage	$V_{DG}$	$\pm 50$	V	
Drain Current	$I_D$	-1	mA	Continuous
Source Current	$I_S$	-1	mA	Continuous
Temperature Endurance Range	$T_{ER}$	-55 to +125	$^{\circ}$ C	
Maximum sensitivity	$S_{MAX}$	0.55	mV/cGy	

**Modes of Operation**
**Irradiation Mode (Sense Mode)**

<sup>1</sup> More information about the purpose of the on-chip diode you can find in the notes section

In this mode of operation, it is recommended that all terminals of the RADFET are connected to ground. For alternative biasing options, contact the manufacturer.

### Read-Out Mode (Accumulated Radiation Dose Read-Out)

The RADFET can be read at arbitrary intervals, depending on the application. The period between readings can be from seconds to days or even months. The circuit used to read out the RADFET (Reader Circuit - RC) is shown in Figure 2 with connection configuration in Table 3.

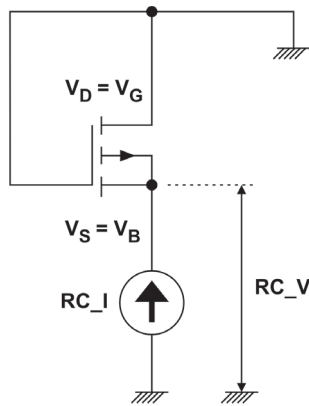
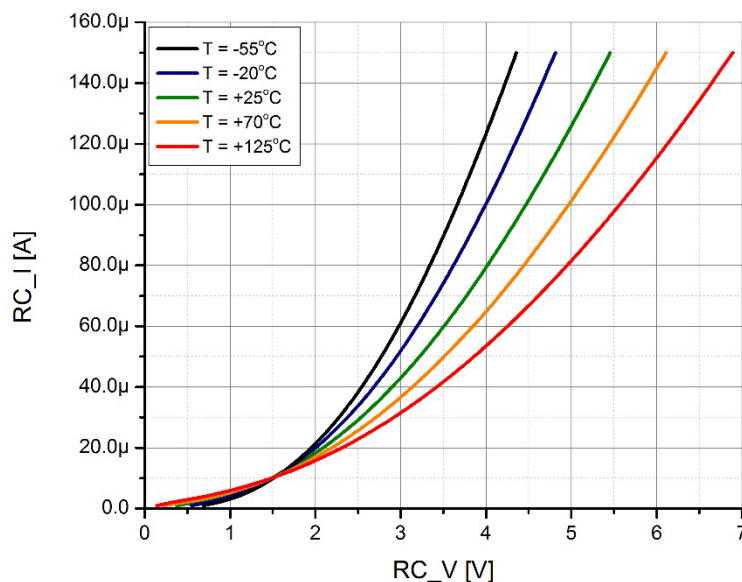

**Table 3:** Connections in Read-Out mode.

Terminal	Bias
S=B	Current is forced (RC_I) Voltage reading is taken (RC_V)
G=D	0 V (common)

**Figure 2:** Reader Circuit (RC) configuration.

Current RC\_I is forced into the RADFET, connected in RC configuration (Figure 2). The voltage at the source (RC\_V) is measured; this voltage is called “RC threshold voltage”. Typical I-V curves at different temperatures for un-irradiated device in this configuration are shown in Figure 3. In principle, any read-out current (RC\_I) value above 5  $\mu\text{A}$  can be chosen, if the value is kept unchanged after the start of radiation exposure. For best temperature compensation, the RC\_I value of 10  $\mu\text{A}$  is recommended where the temperature influence is minimal.



**Figure 3:** Typical Reader Circuit (RC) I-V curves, pre-irradiation. Measured at different temperatures.

## Electrical Parameters

The most important electrical parameter of un-irradiated RADFET is RC threshold voltage (RC\_V). Specification for RC\_V is given in Table 4. Results of RC\_V measurements prior to shipment are included in documentation that comes with ordered parts. Typically, the range of RC\_V of delivered parts is significantly tighter than in the specification.

**Table 4:** Specification for RC threshold voltage. Measured at room temperature.

Parameter	Symbol	Test Circuit and Conditions	Limits		Unit
			Min	Max	
RC Threshold Voltage	RC_V	Figure 2 and Table 3 RC_I = 10 $\mu$ A	0.8	3.0	V

## Calibration Data

The calibration curve for the RADFET shows evolution of  $\Delta V$  (the change in RC threshold voltage with reference to its pre-irradiation value) with dose. Note that a specific calibration curve, obtained using the Co-60 source, is associated with each RADFET production batch. The calibration curve, together with analytical equation and fitting coefficients, will be provided with the supplied parts. For illustration, typical calibration curve is shown in Figure 4.

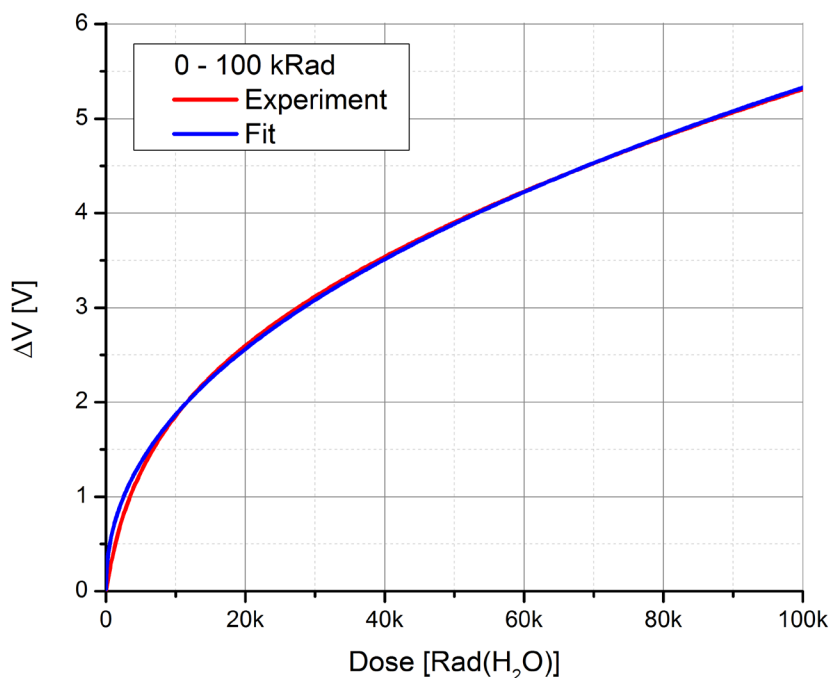

**Figure 4:** Typical calibration curve indicating change in RC\_V during irradiation. Irradiation at room temperature with Co-60 gamma source, dose rate ~50 Gy/h (5 krad/h). Voltage measurements performed at room temperature using 0.2% duty cycle with all terminals grounded between measurements

## Package Information

VT01 package specifications are given in Table 5, and package diagram in Figure 5.

**Table 5:** VT01 package specifications.

Description	Specification
Package Type	Six-pin plastic SOT-23 package
Package Dimensions (L x W x H)	2.90 mm x 2.80 mm x 1.10 mm (see Figure 5)

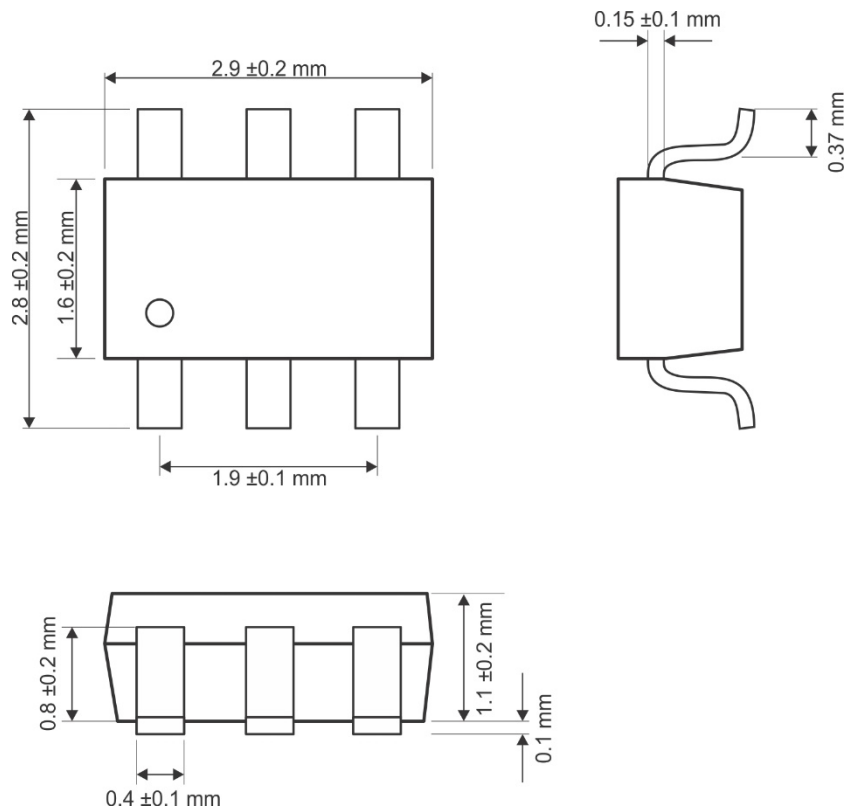

**Figure 5:** VT01 package diagram.

Recommended dimensions for solder pad layout are given Figure 6.

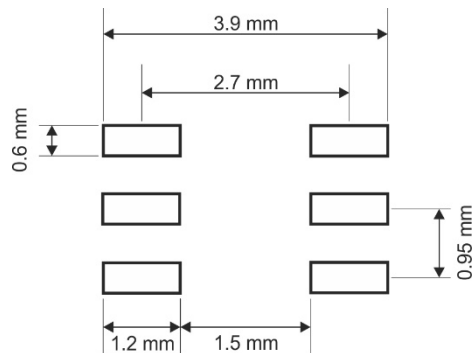

**Figure 6:** Recommended solder pad layout. Dimensions are inclusive of plating.

It is highly recommended to avoid any metal traces below the component. Any metal or high-density material near the component might influence the radiation response and cause deviations from the supplied calibration parameters.

## Handling

Our RADFETs undergo 100% electrical test and visual inspection immediately prior to shipment. Therefore, all parts should reach the customer in excellent condition. To ensure that the RADFETs remain in this condition, please handle the parts as carefully as possible and observe standard precautions related to ESD sensitive devices.

## Soldering

For our RADFETs we strongly recommend hand soldering onto printed circuit boards prior to exposure in radiation field. The temperature used in the soldering should be as low as possible using low-temperature melting point solder alloys. It is a good practice to solder the pins individually with 10sec break between pins, this will prevent overheating of the RADFET die and allow the heat generated from the soldering to dissipate.

It is important that the RADFET is the last component to be soldered onto a circuit board. If different soldering method is required, please contact us at [support@varadis.com](mailto:support@varadis.com).

## Notes

We calibrate our standard products at room temperature using a Co-60 gamma-ray source. Irradiation is performed in a single event at the dose rate of ~50 Gy/hour (5 krad/hour) and includes the dose range from 1–1,000 Gy (100 rad – 100 krad). The voltage measurements are recorded using a 250ms width current pulse. There is a 120second period between measurements when all terminals are grounded – this equals a measurement duty cycle of approximately 0.2%.

Customers whose requirements include conditions significantly different from the above should contact [support@varadis.com](mailto:support@varadis.com) to discuss the optimum way to implement the RADFETs for their specific applications.

The VT01 has a large dynamic range, from 1 cGy (1 rad) to 1 kGy (100 krad) and beyond (with additional calibration).

While the supplied calibration curve covers doses from 1–1,000 Gy, other measurements at room temperature show that lower doses, down to 1 cGy, can be detected. The lower the minimum dose required by the customer, the more accurate must be the RADFET temperature compensation and read-out electronics. Please contact [support@varadis.com](mailto:support@varadis.com) for further details if your application includes lower dose range.

Regarding the high end of the dose range, VT01 can measure doses even higher than 1 kGy (100 krad). However, the sensitivity decreases with dose and it depends on the actual application requirements whether this sensitivity loss is acceptable. As VT01 comes calibrated up to 1 kGy (100 krad), additional calibration is needed for measurements beyond this limit.

The on-chip diode is connected between pin 1 (anode) and pin 2 (cathode). The diode is not sensitive to ionizing radiation in the way the RADFETs are. The diode can be used as an indicator of the chip temperature during irradiation (sense mode).

During RADFET irradiation (sense mode) the diode can be forward biased by forcing positive current into pin1 and the diode voltage obtained at the same pin. It is recommended that after diode forward bias, pin1 is connected back to the ground or remain floating.

During RADFET read-out mode (accumulated radiation dose read-out) the diode **must not** be forward biased as it will influence the RADFET readout voltage and disturb the measurement.

For diode response over a temperature range, and other queries related to this document please contact [support@varadis.com](mailto:support@varadis.com).