

TECHNICAL DATA

RM-VT02-A

VT02 RADFET Readout Module

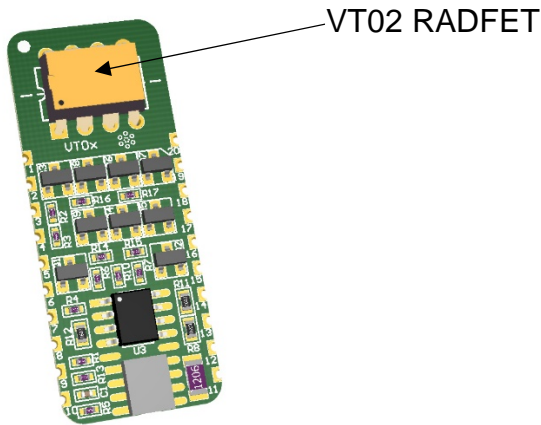

Description

The RM-VT02-A RADFET Read-out Module is a result of many years of experience of Varadis engineers in designing RADFET read-out circuitry. Aimed at providing an optimized RADFET read-out and cutting customers' development time and cost, the RM-VT02-A contains the VT02 RADFET and key circuitry for its readout. The module outputs a buffered analog voltage (RADFET threshold voltage), which is related to accumulated radiation dose of the RADFET. Due to its small size, RM-VT02-A can easily be integrated into customer's system by soldering directly onto the PCB or via a standard through-hole header connector.

RM-VT02-A is specially designed for and optimized around Varadis VT02 RADFET, with current source individually adjusted for each part to minimize RADFET threshold voltage drift due to temperature.

The threshold voltage of the RADFET is buffered for easier integration with standard analog to digital converters, significantly simplifying customer's electronics design.

Both Read-out and Irradiation (sense) modes of RADFET operation are supported. The user can easily select the desired mode by TTL logic level control signals.

Features

- Facilitates optimum RADFET read-out and saves on our customer's development time and costs
- Contains VT02 RADFET and critical read-out circuitry
- Supports Read-out and Irradiation modes of RADFET operation
- Main features:
 - Individually adjusted current source to minimize temperature influence
 - Buffered analog output voltage
 - TTL Logic control
 - Single supply
 - Low power
- Easy integration with customer's system as a surface mounted component or through-hole standard header pin connector
- Dose range from 1 cGy to 1 kGy (1 Rad to 100 kRad)

Typical applications

- General purpose radiation detection
- Satellites
- Medical equipment
- Accelerator facilities
- Nuclear power stations

Connector Assignment and Dimensions

RM-VT02-A connector assignment and PCB outline drawing are given in Figure 1, and pin description in Table 1.

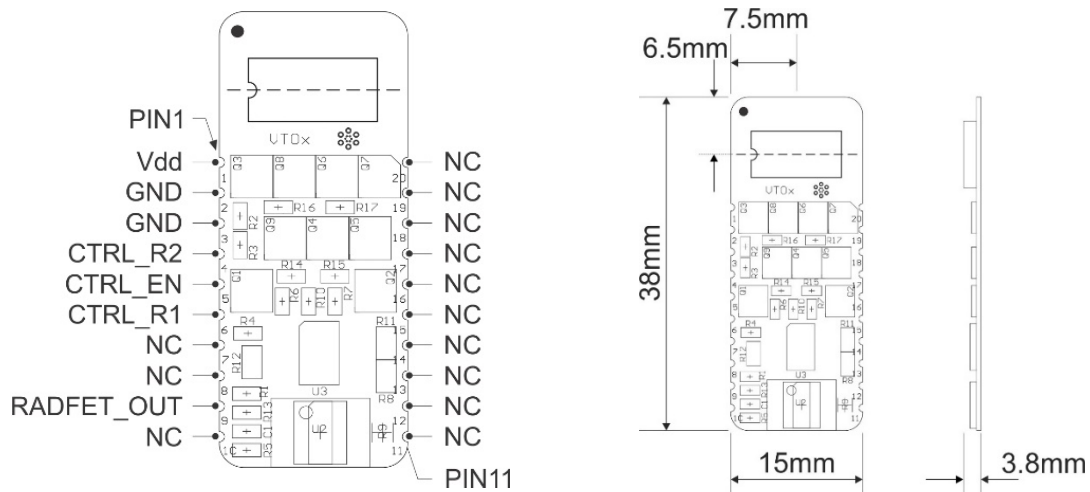

Figure 1: RM-VT02-A connector assignment and PCB outline drawing and dimensions.

Table 1: Pin description.

Pin No.	Pin name	Pin type	Description / Recommendations
1	Vdd	POWER	Positive power supply; this pin must be decoupled with 10 μ F ceramic, low ESR capacitor.
2	GND	GND	Connect to power supply ground.
3	GND	GND	Connect to power supply ground.
4	CTRL_R2	Digital IN	RADFET R2 selection signal.
5	CTRL_EN	Digital IN	Enable signal
6	CTRL_R1	Digital IN	RADFET R1 selection signal.
7	NC	-	Not connected; this pin should be left floating.
8	NC	-	Not connected; this pin should be left floating.
9	RADFET_OUT	Analog OUT	VT02 RADFET output voltage, selectable via control signals.
10-20	NC	-	Not connected; these pins can be left floating or connected to GND.

Block Diagram

The schematic diagram of the RM-VT02-A module is shown in Figure 2.

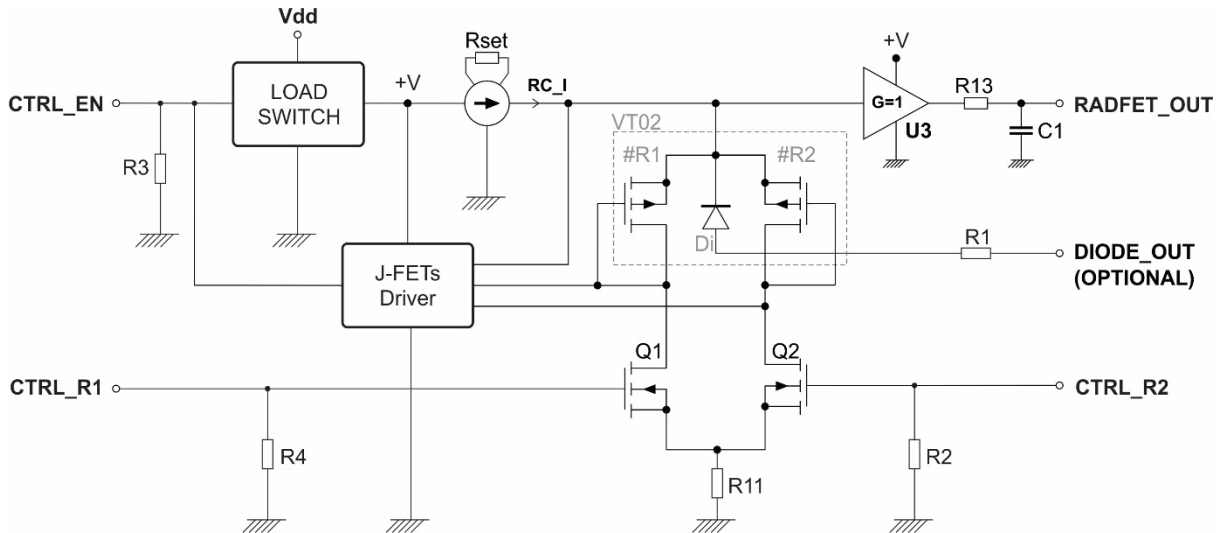

Figure 2: RM-VT02-A schematic diagram.

Operation Principle

The main element of the RM-VT02-A readout module is the VT02 part, operation and specifications of which are described in VT02 datasheet on [“Our Products” web page](#). The part consists of two identical RADFETs, R1 and R2, and a diode. The RM-VT02-A module can be irradiated in active (powered) and passive (unpowered, $V_{dd}=0V$) mode, we recommend using active. Irradiation (sense) and Read-out modes are implemented by a series of analog switches (j-FETs), providing appropriate biasing conditions. Readout configuration is set by control signals CTRL_EN, CTRL_R1 and CTRL_R2 as per truth logic table in Table 2 and 3. In Irradiation mode, all RADFET terminals are grounded. In Read-out mode, the selected RADFET is biased in Reader Circuit configuration – Drain/Gate tied together and grounded, Source/Bulk tied together, constant DC current source connected to Source/Bulk, RADFET Reader Circuit threshold voltage ($RC_V = V_{TH}$) read at Source/Bulk.

The current source on RM-VT02-A is optimized for stability and its current level RC_I is individually adjusted for each VT02 part to minimize temperature drift. The V_{TH} signal is multiplexed, buffered, and filtered, available at Pin 9 (RADFET_OUT).

Table 2: Module operation Truth table.

Active mode of operation	CTRL_EN	CTRL_R2	CTRL_R1	Description
Irradiation (sense)	0	0	0	In irradiation mode all RADFET terminals are grounded
Read-out	1	0 1	0 1	See Table 3 for more details

Table 3: Read-out truth table.

CTRL_EN	CTRL_R2	CTRL_R1	RADFET_OUT	Description
0	0 1	0 1	0 V	RADFETs in irradiation mode (All terminals grounded)
1	0	1	$V_{TH} (R1)$	R1 in Read-out mode, R2 in Irradiation mode
1	1	0	$V_{TH} (R2)$	R1 in Irradiation mode, R2 in Read- out mode
1	1	1	Not allowed ¹	RADFET_OUT invalid

¹ Do not use. It can result in wrong V_{TH} readings.

RADFET Output Voltage Values and Timing

An example of typical voltage output values and enable sequence shown in Figure 3 and 4.

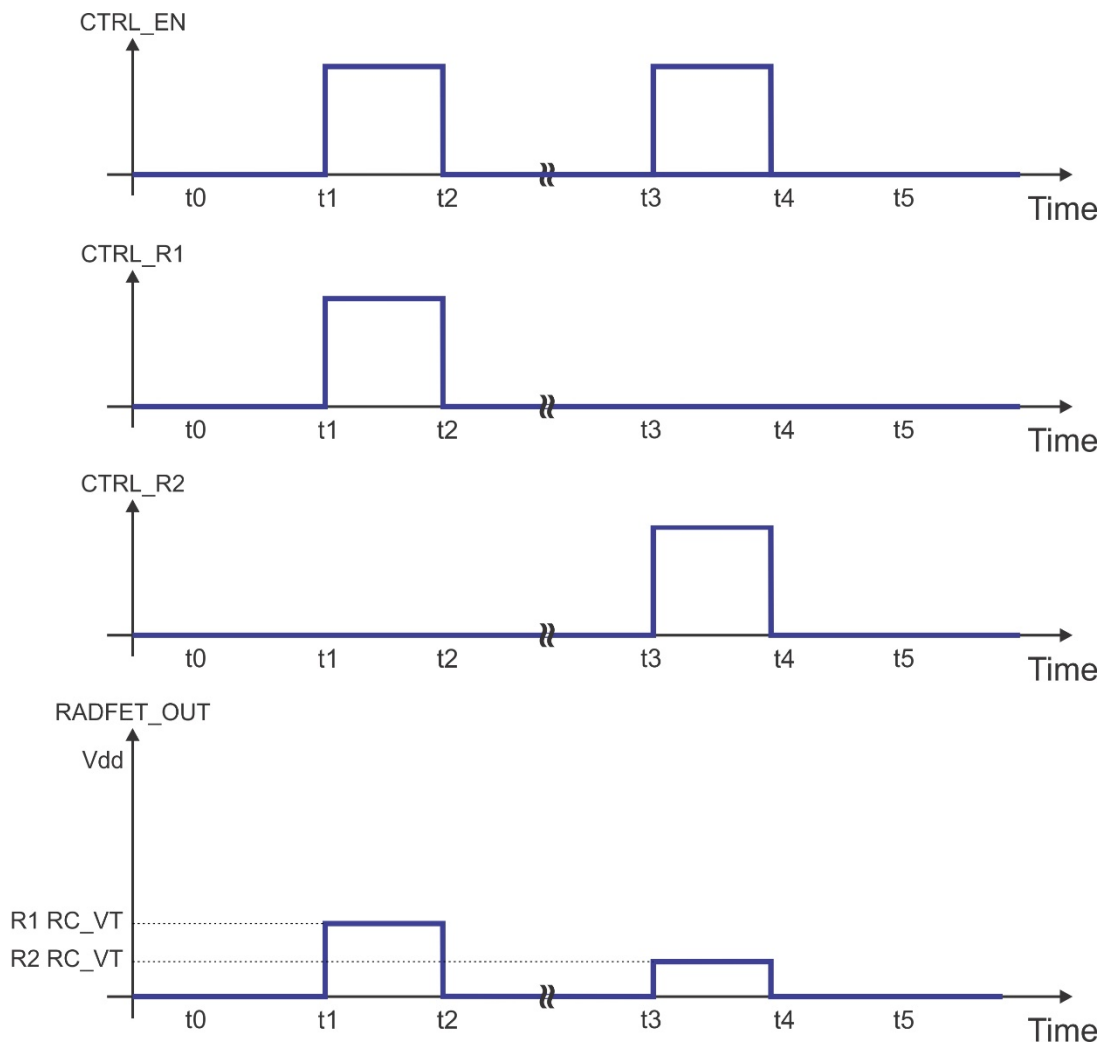
Figure 3: RM-VT02-A Output Voltage Values and Timing example1.

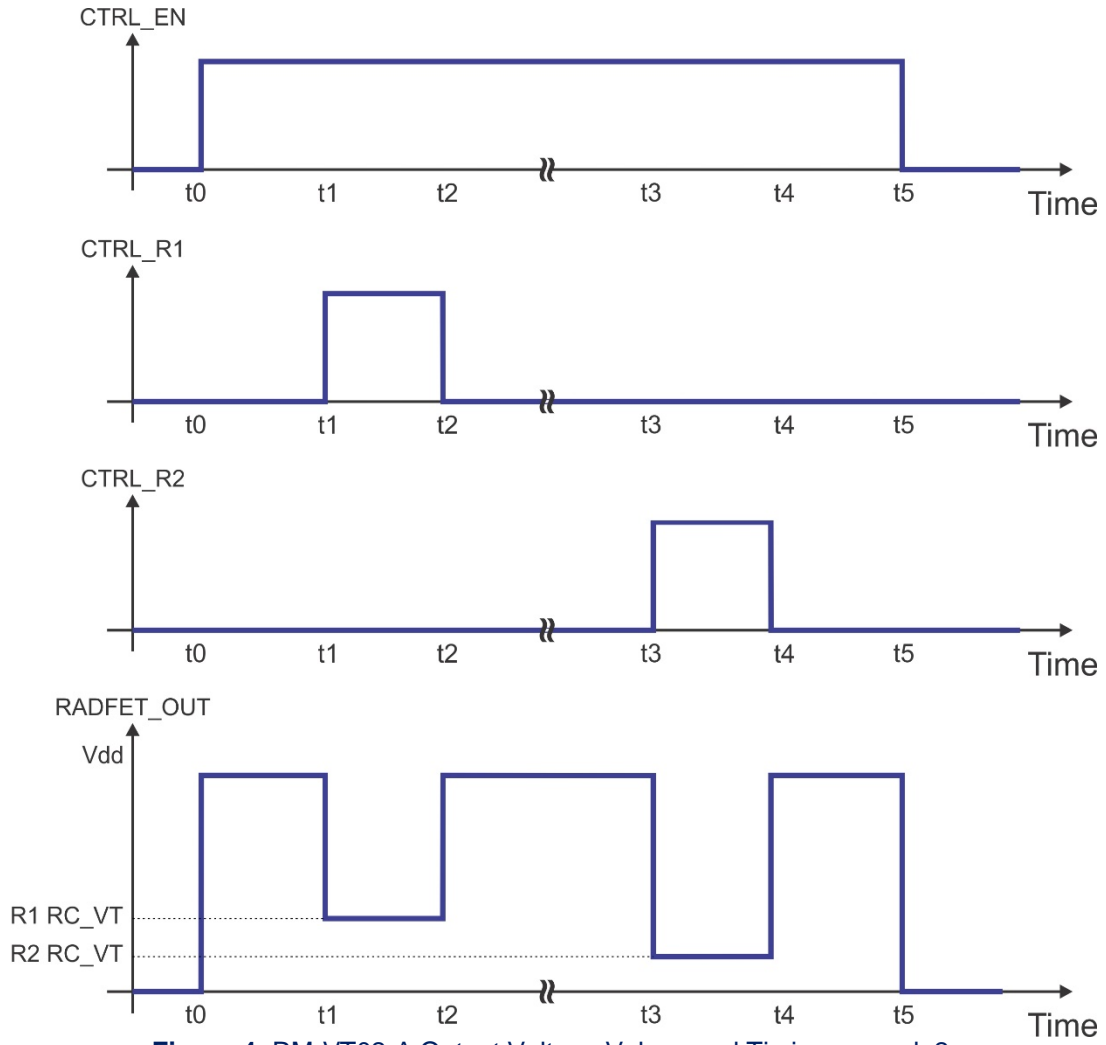

Figure 4: RM-VT02-A Output Voltage Values and Timing example2.

Radiation Calibration Data

The calibration curve for the RM-VT02-A shows evolution of ΔV (**RADFET_OUT pin voltage change with reference to its pre-irradiation value**) with dose. Note that a specific calibration curve, obtained using the Co-60 source, is associated with each RADFET production batch. The calibration curve, together with analytical equation and fitting coefficients, will be provided with the supplied parts. For illustration, a typical calibration curve is shown in Figure 5.

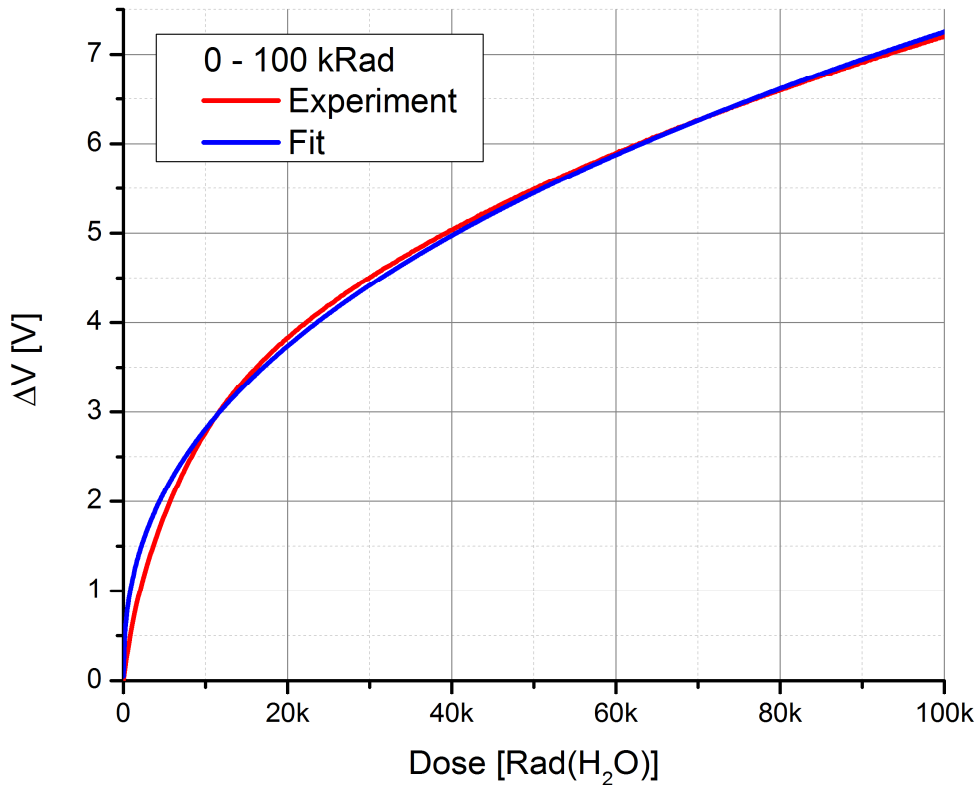

Figure 5: Typical calibration curve indicating change in voltage during irradiation. Irradiation at room temperature with Co-60 gamma source, dose rate ~50 Gy/h (5 krad/h). Voltage measurements performed.

Recommended Operating Conditions

RM-VT02-A module recommended operating conditions are given in Table 4.

Table 4: Recommended operating conditions.

Symbol	Parameter	Value	Unit
V _{DD}	Supply voltage, referenced to GND	12	V
CTRL_EN	Enable signal	5	V
CTRL_R1	RADFET R1 selection signal	5	V
CTRL_R2	RADFET R2 selection signal	5	V
T	Ambient operating temperature	22	°C
ARH	Ambient relative humidity (non-condensing)	< 85	%

DC Electrical Characteristics

RM-VT02-A module DC electrical characteristics are given in Table 5.

Table 5: DC electrical characteristics.

Symbol	Parameter	Conditions	Limits			Unit
			Min	Typ	Max	
V _{DD}	Supply voltage, referenced to GND	T=22°C		12	24	V
I _{DD}	Supply current	CTRL_EN = 1		2		mA
		CTRL_EN = 0			0.1	µA
V _{TH}	RADFET threshold voltage ¹	I _{out} = -0.1mA	0.8	1.8	V _{DD}	V
I _L	Output load current		0	-0.1	-1	mA
V _{CTRL_R1} V _{CTRL_R2}	Control signal voltage		3	5	V _{DD} - 1	V
V _{CTRL_EN}	Module enable voltage		3	5	V _{DD} - 1	V
T _{ON}	CTRL_R1, CTRL_R2 on time		0.025	0.25	1	s
T _{OFF}	CTRL_R1, CTRL_R2 off time		15			s

Notes:

¹ The RADFET threshold voltage is dependent on accumulated radiation dose, please see VT02 datasheet for more details.

Recommended Circuit Interface

An example of a circuit interface is shown in Figure 6.

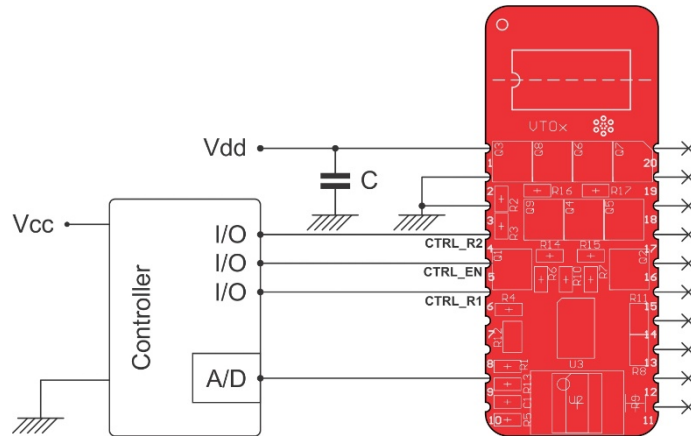

Figure 6: RM-VT02-A interface with microcontroller.

Soldering and Mounting

It is important that the RM-VT02-A is the last component to be hand soldered onto a circuit board. If a different soldering profile is required, please contact us at support@varadis.com. RM-VT02-A can be soldered directly on the customer PCB (treated as SMD) or via standard through hole 10-pin header connector with a pitch of 2.54 mm; example (Mfr. No: 1-826629-0). Recommended dimensions for solder pad layout are given in Figure 7.

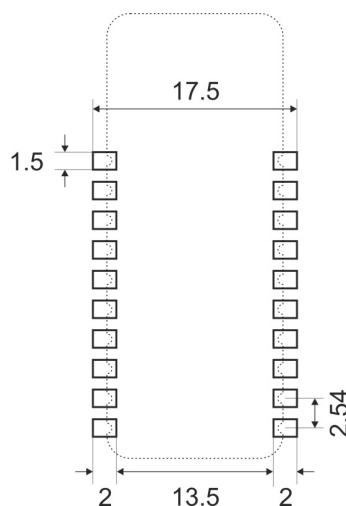

Figure 7: Recommended solder pad layout. All dimensions are in millimeters. Note the drawing is not to scale.

Handling

All assembled boards undergo 100% electrical test and visual inspection immediately prior to shipment. Therefore, all boards should reach the customer in excellent condition. To ensure that the boards remain in this condition, please handle the parts as carefully as possible and observe standard precautions related to ESD sensitive devices.

Notes

Varadis Ltd and its subsidiaries reserve the right to make changes, corrections, enhancements, modifications, and improvements to Varadis products and/or to this document at any time without notice. Purchasers should obtain the latest relevant information on Varadis products before placing orders. Varadis products are sold pursuant to the Varadis terms and conditions of sale in place at the time of order acknowledgement.

Purchasers are solely responsible for the choice, selection, and use of Varadis products and Varadis assumes no liability for application assistance or the design of Purchasers' products.

No license, express or implied, to any intellectual property right is granted by Varadis herein. Resale of Varadis products with provisions different from the information set forth herein shall void any warranty granted by Varadis for such product.

Varadis and the Varadis logo are trademarks of Varadis. All other product or service names are the property of their respective owners. Information in this document supersedes and replaces information previously supplied in any prior versions of this document.